

# SLAPO TYP 1 AC01

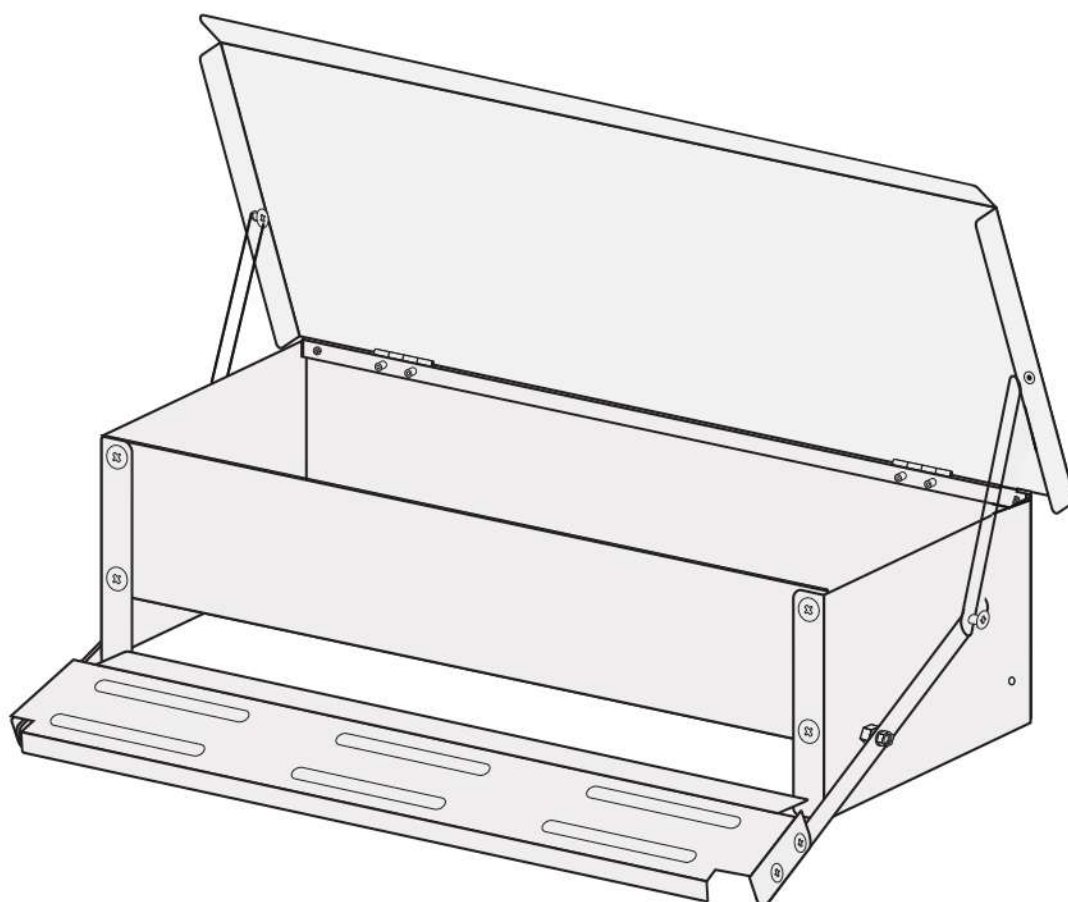

Ax1

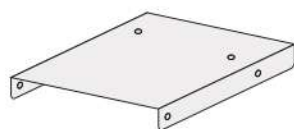

Bx2



Dx2



Ex2

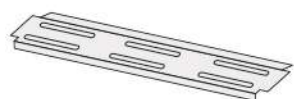

Fx1



M1x16

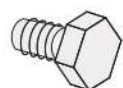

M2x2



M3x2



M4x2



M5x8

1

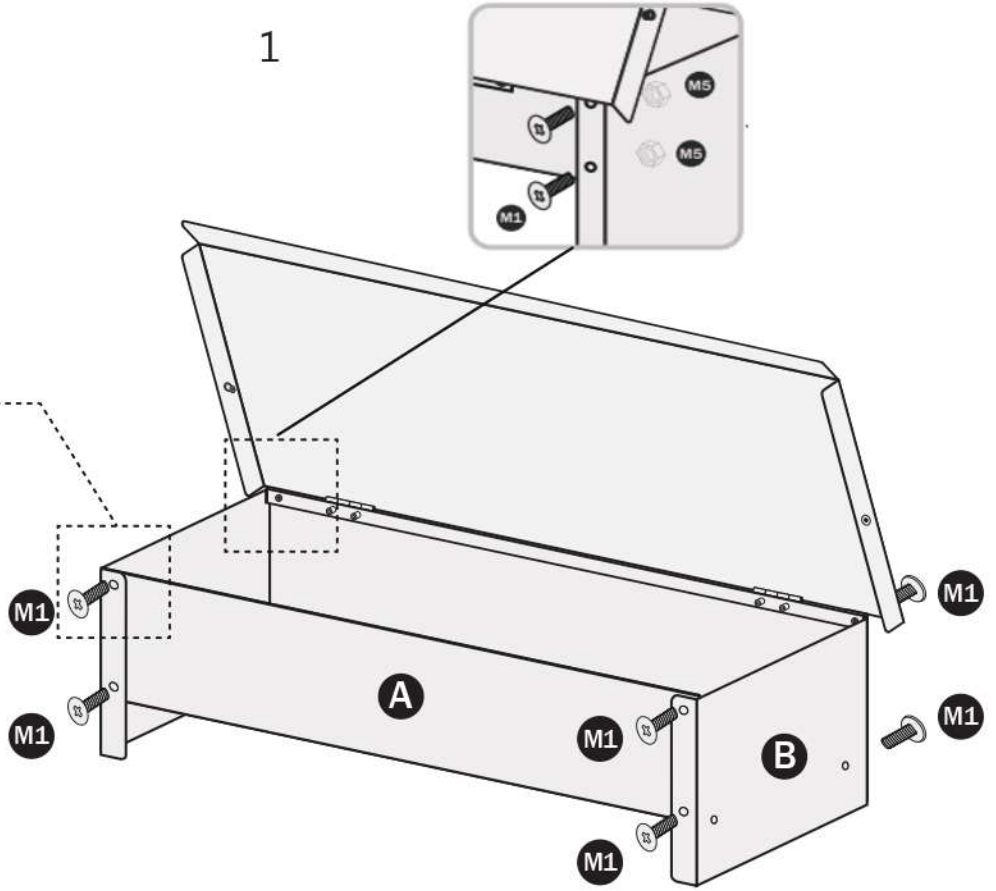
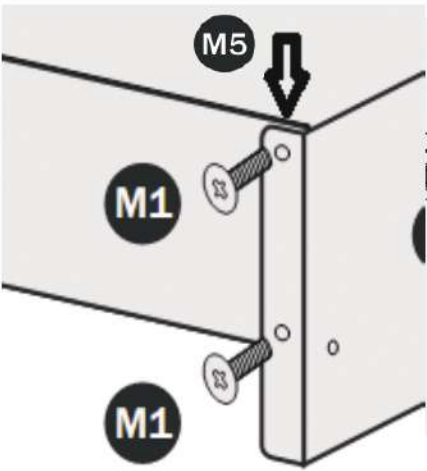
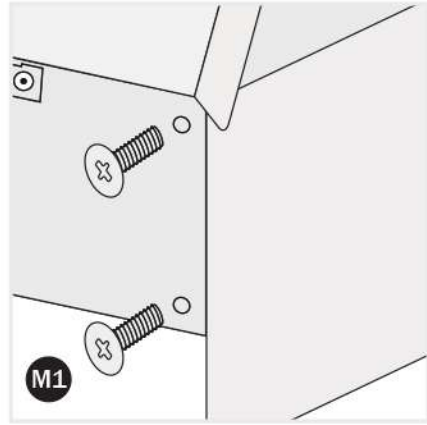

2

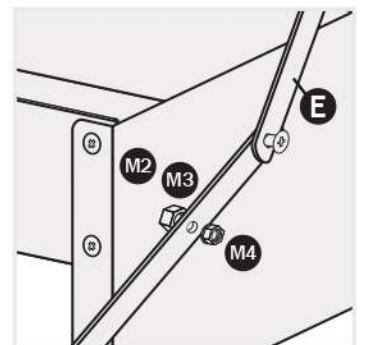
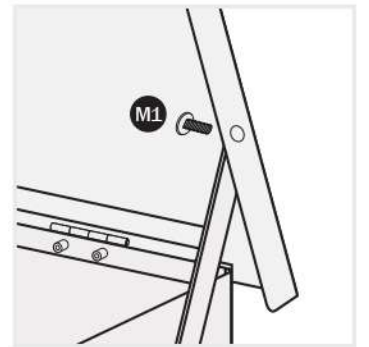
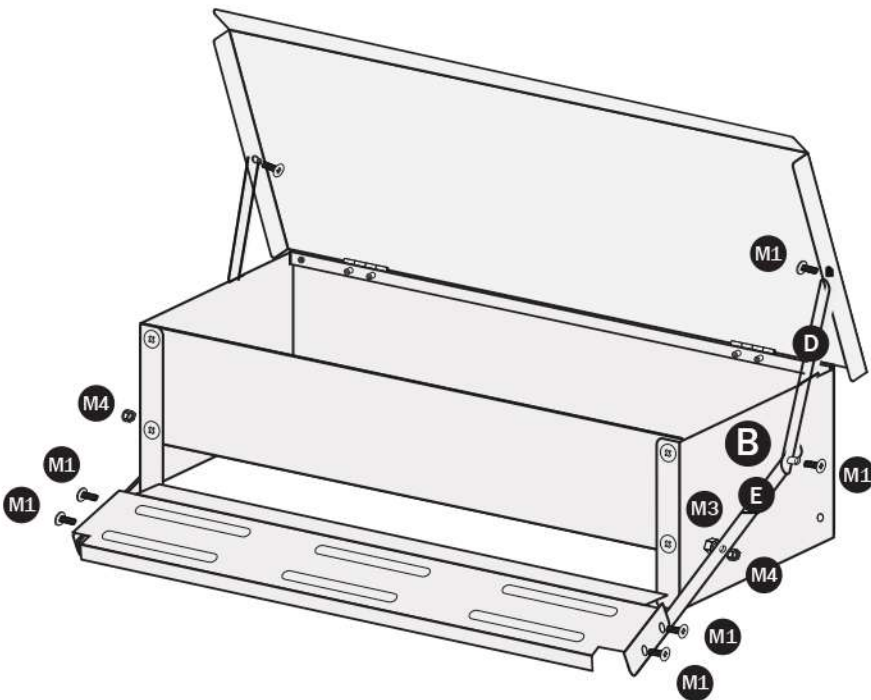

Poznámka: Nechajte menší priestor medzi časťou B a železnou tyčou E a medzi skrutkou M3 a skrutkou M4 (M4 má na jednej strane zarážku, aby sa predišlo vyskrutkovaniu niektorých skrutiek. Skrutka M4 je hrubšia a mala by byť umiestnená vonku).